

N°2 Prese di pressione
7/16"UNF - 1/4"SAE
con tappo SW 14

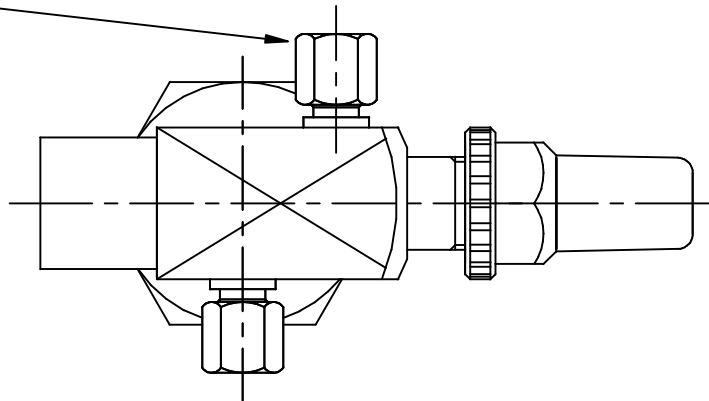

CODICE	ODS	ϕ_i	ϕ_e	ϕ_p	A	B	C	D
43600	16	16.2	20	15	40	57	129	15
43601	18	18.25	22	17	40	57	129	15
43602	3/4"	19.3	22	18	40	57	129	16
43603	22	22.25	26	18	40	57	129	20
43604	7/8"	22.45	26	18	40	57	129	20
43605	28	28.3	32	18	53	70	142	20
43606	1 1/8"	28.85	32	18	53	70	142	20

-ACCESSORIO A PRESSIONE DI ART.3-PAR.3 SECONDO DIRETTIVA 97/23/CE

denaline s.p.a. - PORDENONE - ITALY			DATA	TIPO DI MODIFICA	REV.
	SCALA	1:1.5			
MAT. CORPO : 11SMnPb37 UNI EN 10277-3	DISEGNATO	Bortolotto.M			
TOLL. GENERALI: ± 0.1 TOLL. ANG.: $\pm 1^\circ$	APPROVATO				
COMPONENTE ESENTE DA DIFETTI : ES. BAVE, RUGGINE E INCRINATURE	REVISIONE N°	0	06/09/02	EMISSIONE DISEGNO	0
	DENOMINAZIONE	Valvola Q30 rotalock 1 3/4" -12 UN con ODS e 1P.P. Dx + 1P.P. Sx in By Pass			436--
CODICE	436--				