

Fil. 1 1/4"-12 UNF 2B

SW 24
SW 36

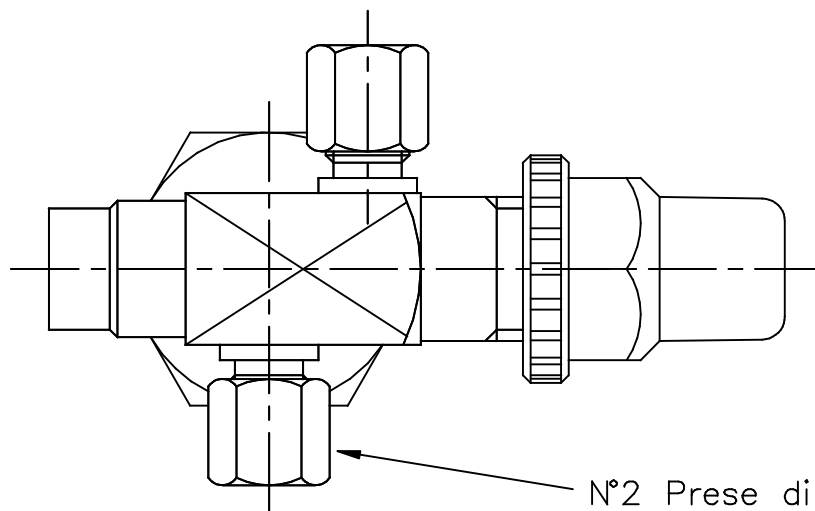

N°2 Prese di pressione
7/16"UNF - 1/4"SAE
con tappo SW 14

CODICE	ODS	δi	δe	δp	A	B	C	D
39101	10	10.2	13	9	26	39	94	10
39102	12	12.25	16	11	29	42	97	14
39105	16	16.2	19	11	29	42	97	15
39106	18	18.25	22	11	31	44	99	15
39107	1/2"	12.95	16	11	29	42	97	14
39108	3/4"	19.3	22	11	31	44	99	16

-ACCESSORIO A PRESSIONE DI ART.3-PAR.3 SECONDO DIRETTIVA 97/23/CE

denaline s.p.a. - PORDENONE - ITALY			DATA	TIPO DI MODIFICA	REV.
	SCALA	1:1			
MAT. CORPO : 11SMnPb37 UNI EN 10277-3	DISEGNATO	Bortolotto.M			
TOLL. GENERALI: ± 0.1 TOLL. ANG.: $\pm 1^\circ$	APPROVATO				
COMPONENTE ESENTE DA DIFETTI : ES. BAVE, RUGGINE E INCRINATURE	REVISIONE N°	0	04/09/02	EMISSIONE DISEGNO	0
	DENOMINAZIONE	Valvola Q20 rotalock 1 1/4" -12 UNF con ODS e 1P.P. Dx + 1P.P. Sx in By Pass			391 --
CODICE	391 --				