

Pohled znázorněn bez ventilátoru
View without fan

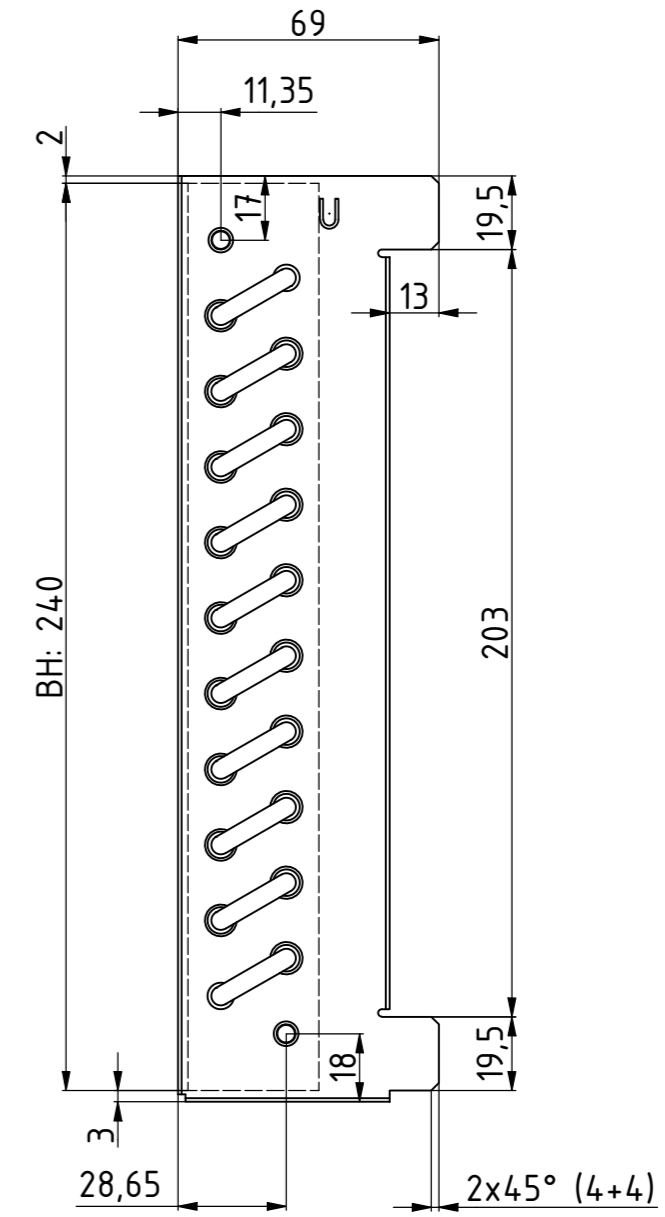

Tulipány: 15 (Tulips oversize)
Přesah oblouků: 28-2 (U-bends oversize)

Přesah vlásenek: 14+1 (Hairpins oversize)

Diagram

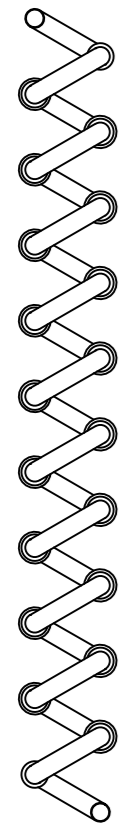

Směr vzduchu

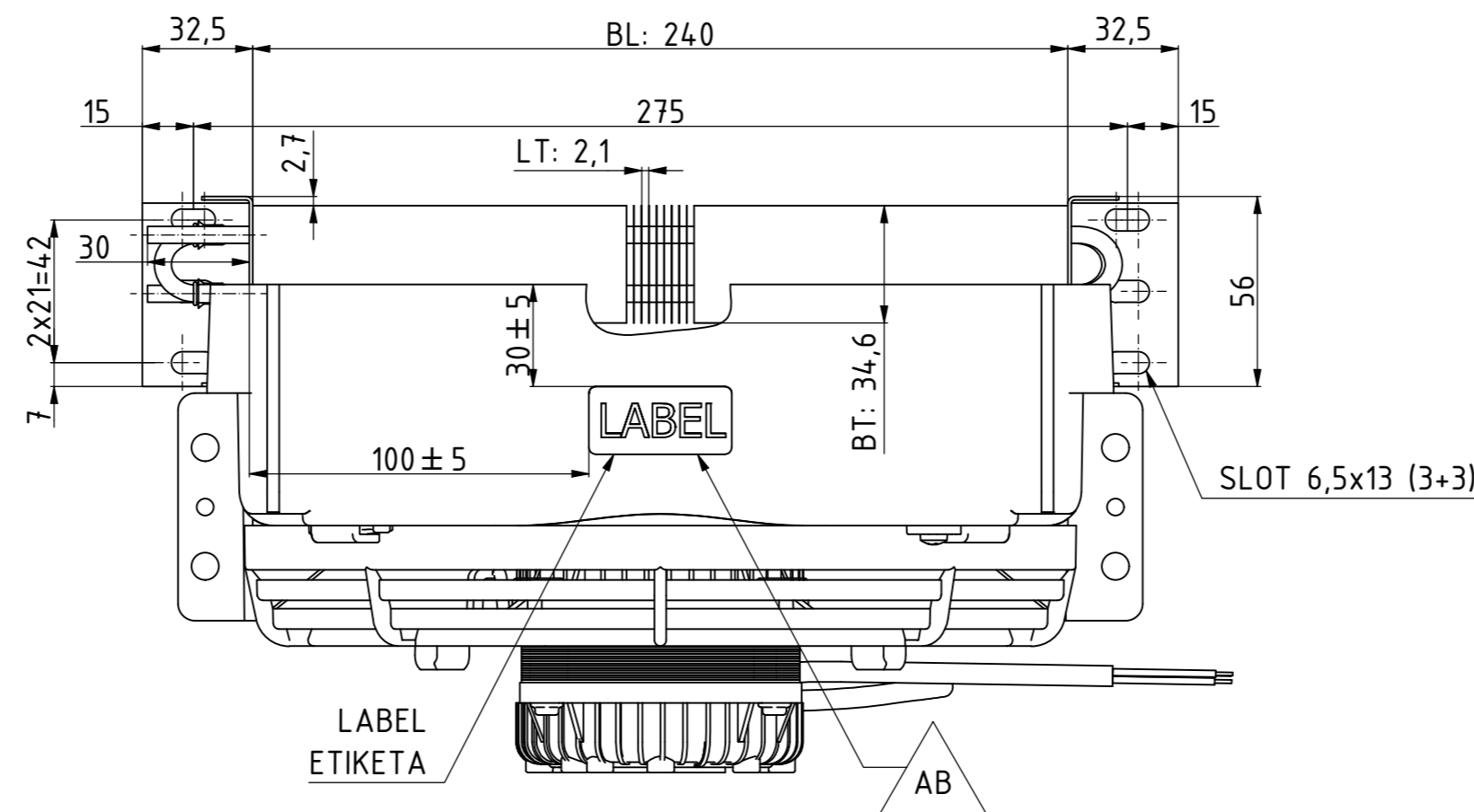

Ventilátor 7W, 220V

Montáž oběžného
kola dle TSI 405.

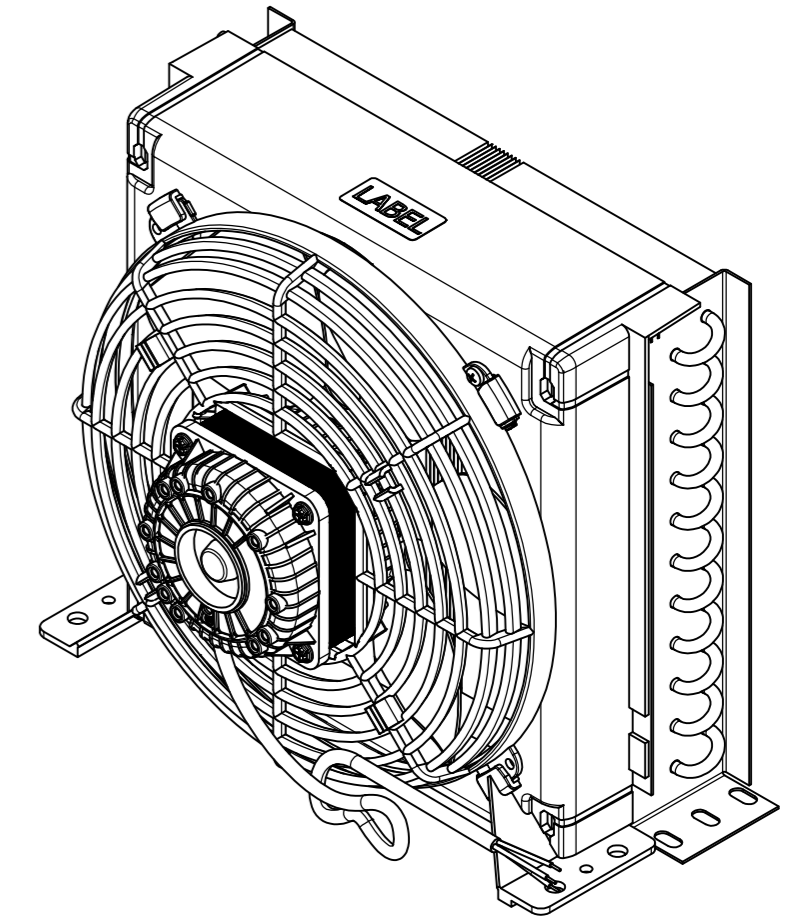

ONLY FOR HTS

Label Type 01
according
specification
KN 4000

AB

CUSTOMER MATERIAL CODE CAVF 92	TEST PRESSURE 30 Bar	GEOMETRY	TUBE CU Ø5	Grooved
CUSTOMER DRAWING Nr	PS REF. TO PED 27 Bar	TUBE x ROW SPACE 20x17,3 mm	FINS AL	Louvered
NITROGEN CHARGE YES	DESIGN PRESSURE REF. TO UL 27 Bar	Nr OF TUBES Nr OF ROWS 12 2	END PLATES	Thk. 1 mm FEZN
REFRIGERANT PEDGr2 - PED FLUID GROUP 2	TS MIN TS MAX -40 °C +125 °C	FIN SPACE 2,1 mm	COVER PLATES	---

STATUS: Pending	CHANGE NR.: AB	CHANGE REASON: ZR106/24 New drawing stamp, label.	CHANGE DATE-HOUR: 04-Mar-2024 12:32	ISSUE: 01
GENERAL TOL.: ISO 2768-c	PROJECTION: ⊕	MATERIAL CODE: 10143254	CUSTOMER: FRIGO PLUS	
DESCRIPTION: 05G1720P021L0240R02T12C0F0				
TREATMENT: -----	COLOR: -----			
WEIGHT: 3,2 kg	DRAW DATE: 28/02/2024	APPROVED BY: T.Vasicek	DRAW BY: P.Klein	
Novosedly na Moravě 238 (ZIP Code 691 62) Czech Republic Tel: 00420519501401 - Fax: 00420519501403 www.htsystems.cz - e-mail: HTS@luvegroup.com				

This drawing is the property of LU-VE Group, any reproduction and/or distribution without LU-VE Group approval is unlawful.

DIAGRAM ZAPOJENÍ VLÁSENEK A OBLOUKŮ

SAP číslo výměníku: **10143254/AB**

HAIRPIN SIDE VIEW
Pohled VLÁSENKY
30234165/AB

U-BEND SIDE VIEW
Pohled U-OBLOUKY
30234164/AB

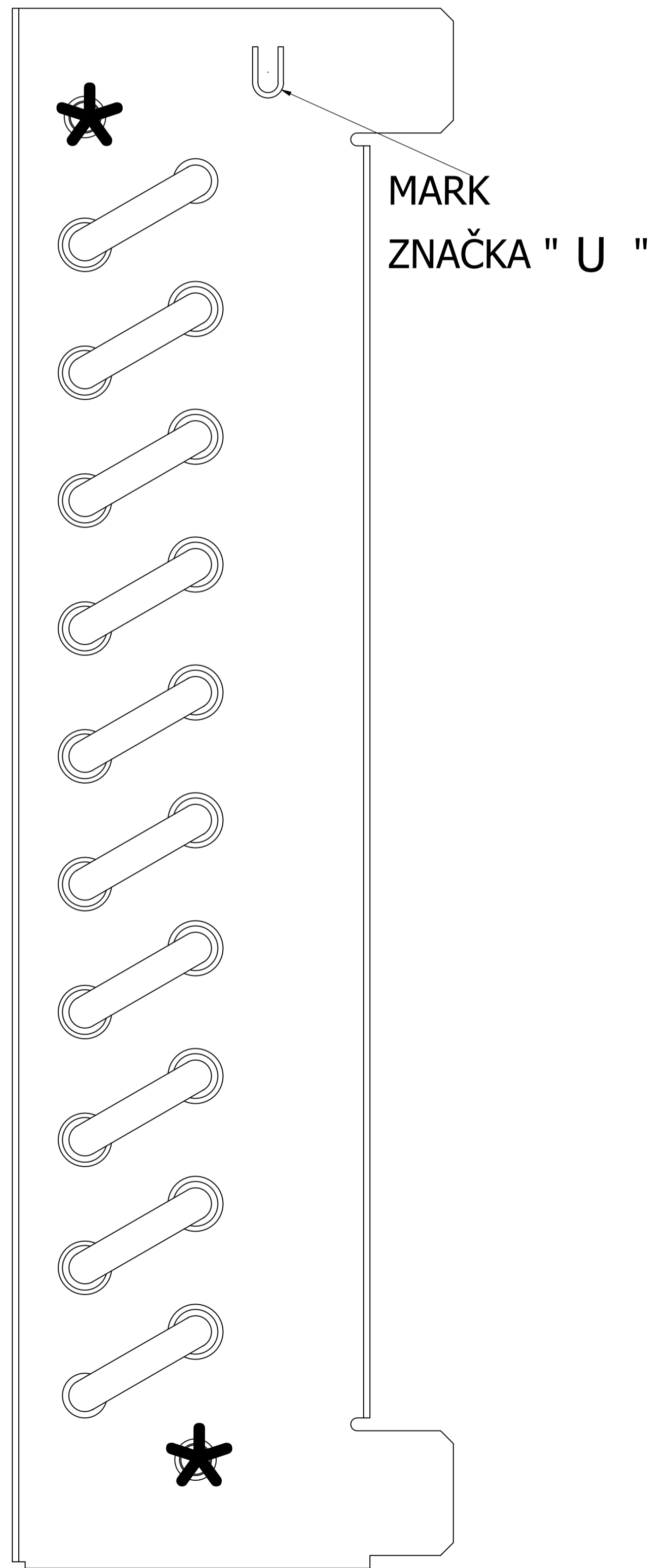
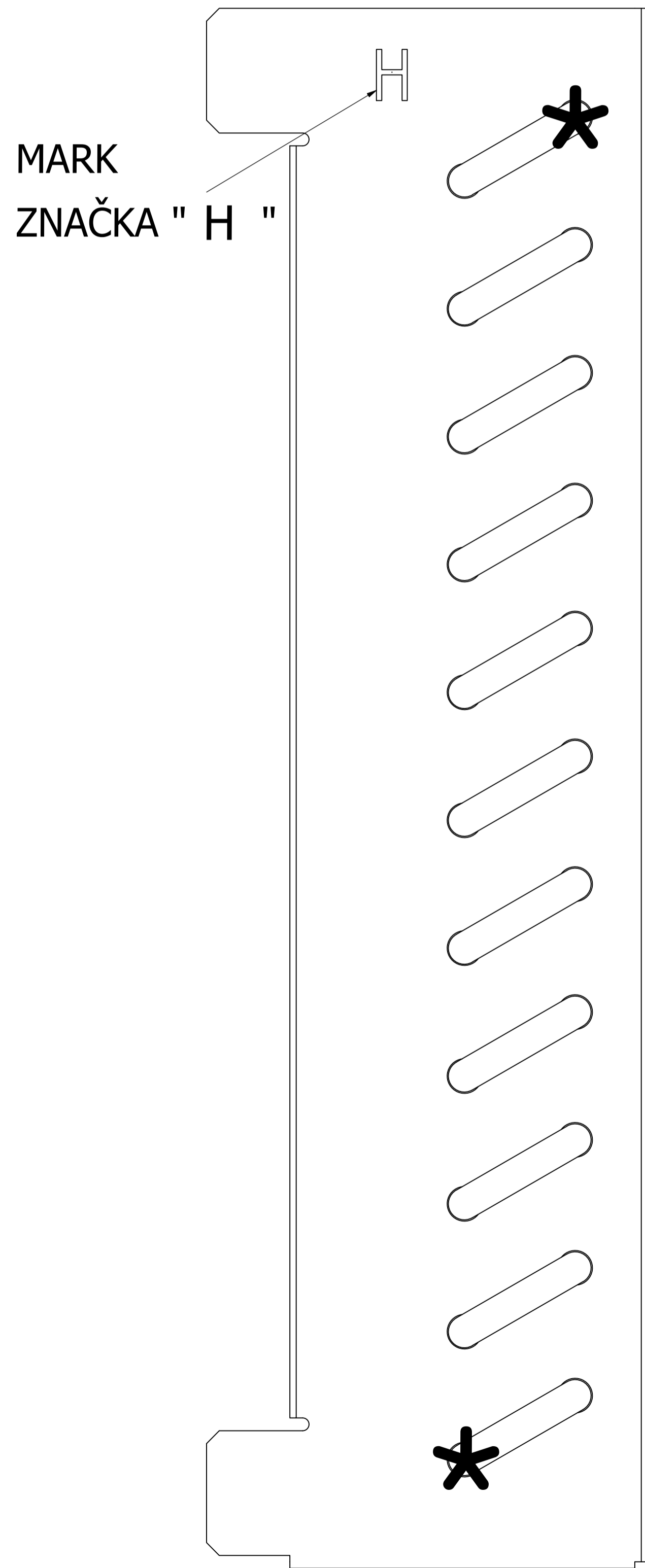

* Neosazovat zvonkovačem - vlásenka s korekcí

POS.	TITLE	DESCRIPTION	MATERIAL	SAP Nr.	REV.	Ks.
10	FIN BLOCK_20x17,3_L_021_12_2_240_0		Všeobecné	31091741	AA	1
20	HP_Cu_G_Ø5x0.21/0.15_20_574_283	Tube Ø5x0,21/0,15-574	Copper	31712302	AA	9
30	E PLATE_U_T12R2Ø5_20x17_FeZn		FeZn,DIN EN 10142 DX51D+Z200-N-A	30234164	AB	1
40	E PLATE_H_T12R2Ø5_20x17_FeZn		FeZn,DIN EN 10142 DX51D+Z200-N-A	30234165	AB	1
50	HAIRPIN_CU_G_D5X0.21/0.15_20_283_0_R15		Cu - DIN EN 12735	30248922	AA	2
60	BEND_D5_X0.5_Cu_20_H19_with solder	Tr. 5x0,5-44,4	Cu - DIN EN 12735	32011254	AA	10
70	VENTOLA DIAM. 230-26-5A		Výchozí	30087534	AB	1
80	ELEC MOT_W7_4_230/1_172/200/23		Generic	30094120	AA	1
90	GRIGLIA CF24 (N.F.S.)	FAN GRID CF 24	PET Plastic	30087580	AB	1
100	SCREW_SELF_D_4,2_X9,5_A2_DIN7981 C-H	-	Nerezavějící ocel	30228163	AA	1
110	CONVOGLIATORE CF24 (N.F.S.)	FAN COVER CF 21	PET Plastic	30087575	AB	1
120	STICKER HTS-OEM_42x20mm		Generico	30228121	AB	1

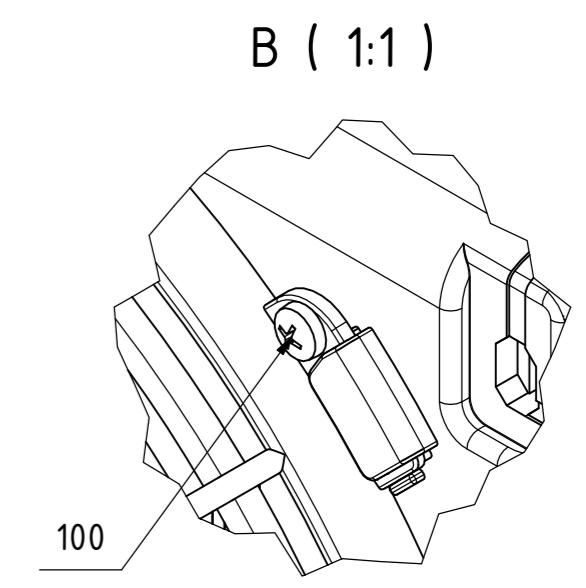
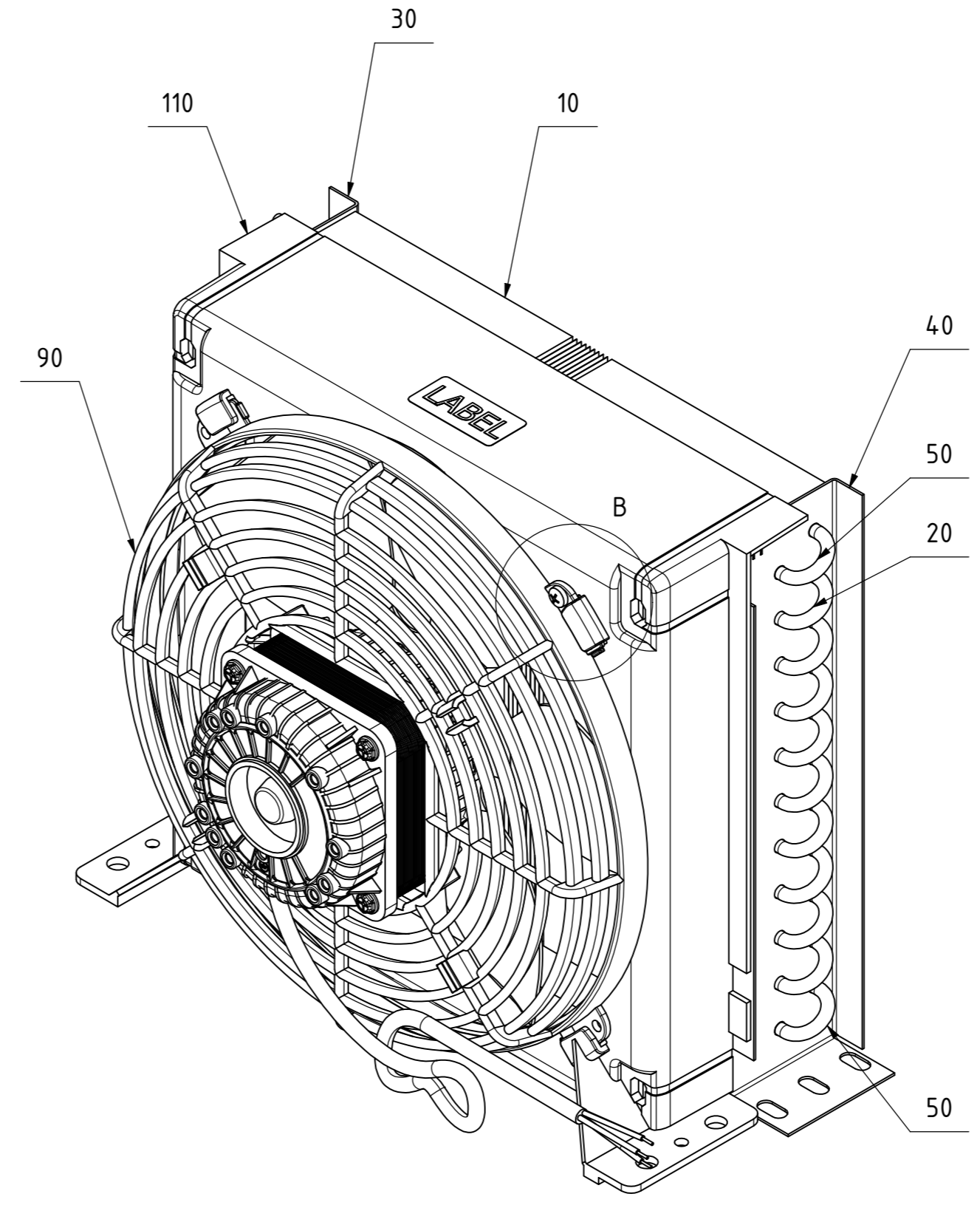
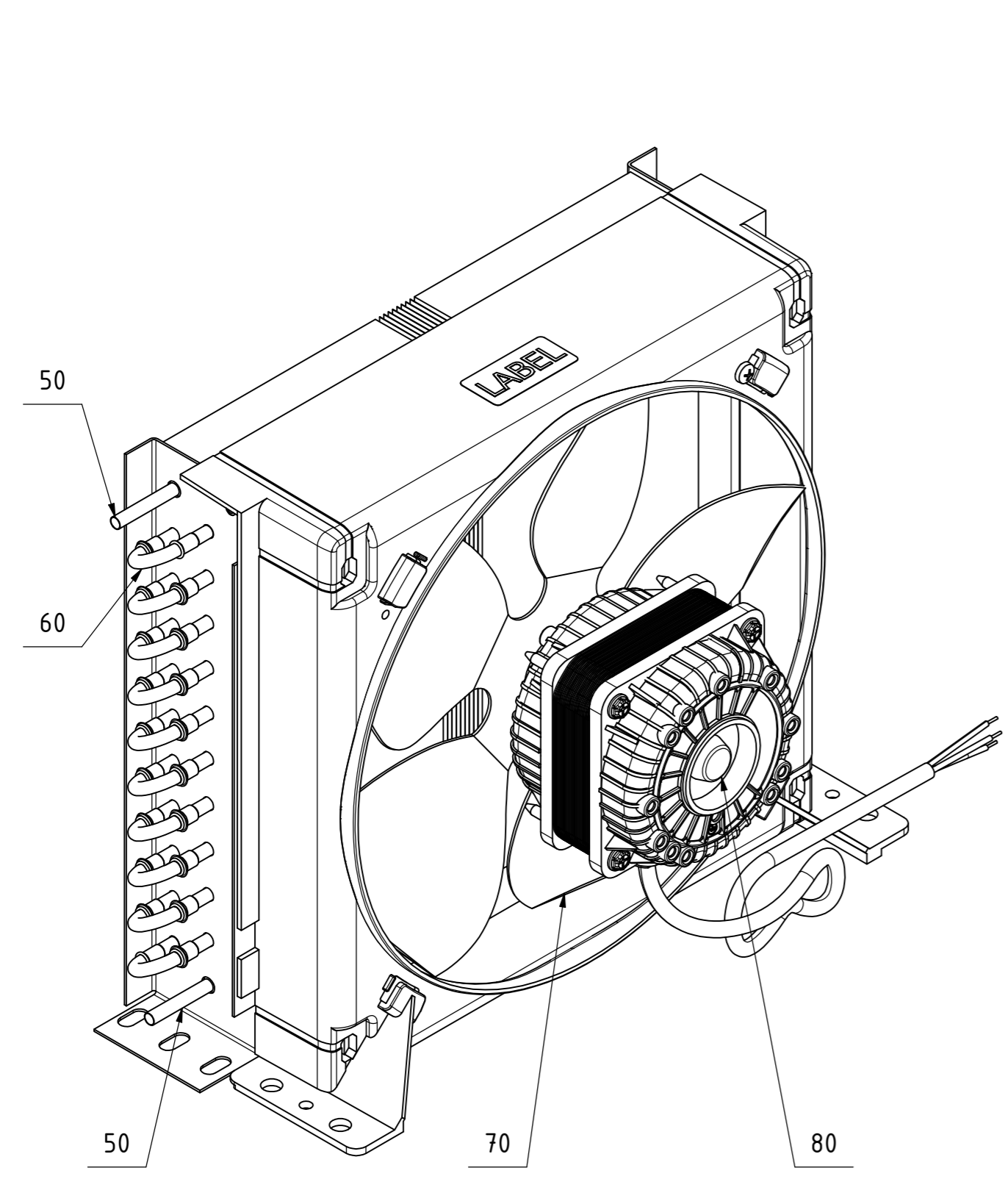
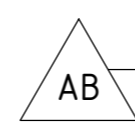
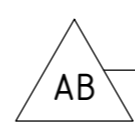

STATUS: Pending	CHANGE NR.: AB	CHANGE REASON: ZR106/24 New drawing stamp, label.	CHANGE DATE-HOUR: 04-Mar-2024 12:32	ISSUE: 01
--------------------	-------------------	--	--	--------------

CUSTOMER MATERIAL CODE CAVF 92	TEST PRESSURE 30 Bar	GEOMETRY	TUBE CU Ø5 Grooved
CUSTOMER DRAWING Nr	PS REF. TO PED 27 Bar	TUBE x ROW SPACE 20x17,3 mm	FINS AL Louvered
NITROGEN CHARGE YES	DESIGN PRESSURE REF. TO UL 27 Bar	Nr OF TUBES Nr OF ROWS 12 2	END PLATES Thk. 1 mm FEZN
REFRIGERANT PEDGr2 - PED FLUID GROUP 2	TS MIN TS MAX -40 °C +125 °C	FIN SPACE 2,1 mm	COVER PLATES ---

GENERAL TOL.: ISO 2768-c	PROJECTION: 	MATERIAL CODE: 10143254	CUSTOMER: FRIGO PLUS
DESCRIPTION: 05G1720P021L0240R02T12C0F0			
TREATMENT: -----	COLOR: -----	Heat Transfer Systems, s.r.o. Novosedly na Moravě 238 (ZIP Code 691 62) Czech Republic Tel: 00420519501401 - Fax: 00420519501403 www.htsystems.cz - e-mail: HTS@luvegroup.com	
WEIGHT: 3,2 kg	DRAW DATE: 28/02/2024	APPROVED BY: T.Vasicek	DRAW BY: P.Klein

TOLERANCES FOR CONNECTIONS UNLESS OTHERWISE SPECIFIED: ±3 mm, ±3° Technical specification according SPEC1 - Last rev.