



Refrigerant	R407C Dew Point
High Side Properties:	
Condensing Temperature, °C	45.00
Abs. Condensing Pressure, bar	17.51
Dew Point, °C	45.00
Bubble Point, °C	40.10
Saturated vapour enthalpy, kJ/kg	425.00
Specific volume of saturated vapour, dm ³ /kg	12.70
Low Side Properties:	
Evaporating Temperature, °C	0.00
Evaporating Abs. Pressure, bar	4.61
Dew Point, °C	0.00
Bubble Point, °C	-6.30
With vapour at, °C	10.00
Specific volume, dm ³ /kg	53.50
Enthalpy, kJ/kg	418.00
Operating Conditions:	
Evaporating Temperature, °C	0.00
Condensing Temperature, °C	45.00
Suction Superheat, K	10.00
Subcooling, K	0.00
Compressor Selected	ZR250KCE-TWD

**PERFORMANCE AT SPECIFIED OPERATING POINT
ZR250KCE-TWD Data at 50 Hz**

Cooling Capacity, kW	45.90
Power, kW	14.35
COP	3.20
Current at 400 V, A	25.24
Suction Mass Flow, g/s	291.00
Heating Capacity, kW	59.50

COMPRESSOR MECHANICAL AND PHYSICAL DATA

Displacement @ 50 Hz, m ³ /h	56.6
Length/Width, mm	427/376
Height, mm	726
Net Weight, kg	138
Gross Weight, kg	168
Rotalock Suction, inch	2 1/4 x 12 UN
Rotalock Discharge, inch	1 3/4 x 12 UN
Stub Suction, inch	1 5/8
Stub Discharge, inch	1 3/8
Oil Quantity, l	4.67
Oil type (original charge)	POE RL32-3MAF
Oil type (approved oils)	POE RL32-3MAF, POE MOBIL EAL Arctic 22 CC
Base mounting (hole dia), mm	266.7 x 266.7 (22.6)
Sound Pressure @ 1m (HT), dBA	72
Sound Power (HT), dBA	83
Sound Conditions (HT, Temperatures:	7 / 54 / 18 °C at 50 Hz
Evap./Cond./Suction at freq./speed)	
PED Category	2
Max. Internal Free Volume, l	24.6
High Side PS gauge, bar	32
Low Side PS gauge, bar	20
Low Side TS Max., °C	52
Low Side TS Min., °C	-35
Refrigerant's GWP	1774
Refrigerant's classification	A1

COMPRESSOR ELECTRICAL DATA (380-420 V / 3~ / 50 Hz)

Maximum Operating Current, A	42
Locked Rotor Current, A	225
Winding Resistance, ohm	0.63
Default Enclosure Class	IP 54 (IEC 34)

ACCESSORIES INCLUDED

Discharge Temperature Protection	Internal Thermistor
Discharge Temperature Protection	PTC in Scroll Discharge Port
Enclosure Class	IP 54
Motor Protection Device	INT69SC2
Mounting Grommets	Standard
Oil Charge	
Oil Service Valve	Schraeder Valve
Check Valve	Discharge Low Leak Check Valve

ACCESSORIES OPTIONAL

Crankcase Heater	102 W External
Crankcase Heater	83 W External
Mounting Grommets	Rubber Grommet For Single
Mounting Grommets	Rubber Grommet For Parallel
Adapter Kit	Operation
Oil Control System	R1"3/4 - B1"3/8 For TPTL for
	Parallel Operation
ALCO Trax-Oil OM3	

ZH 100 KCE
 ZP 235 KCE
 ZR 250 KCE

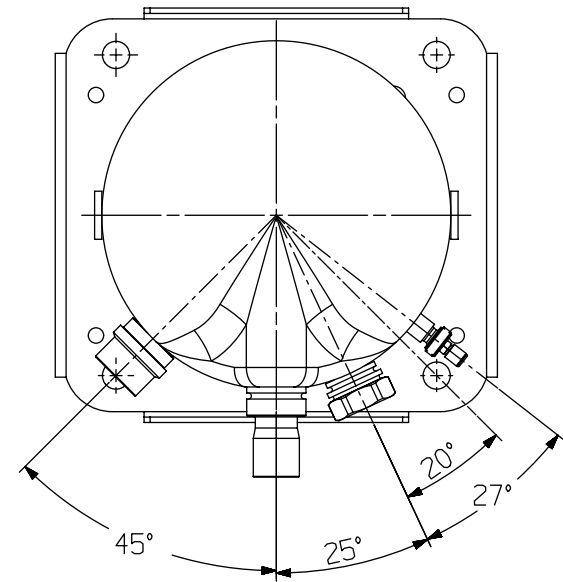

(VIEW W/O TERMINAL BOX)

